

3

91526



NEW ZEALAND QUALIFICATIONS AUTHORITY
MANA TOHU MĀTAURANGA O AOTEAROA

QUALIFY FOR THE FUTURE WORLD
KIA NOHO TAKATŪ KI TŌ ĀMUA AO!

SUPERVISOR'S USE ONLY

Level 3 Physics, 2019

91526 Demonstrate understanding of electrical systems

2.00 p.m. Wednesday 20 November 2019
Credits: Six

Achievement	Achievement with Merit	Achievement with Excellence
Demonstrate understanding of electrical systems.	Demonstrate in-depth understanding of electrical systems.	Demonstrate comprehensive understanding of electrical systems.

Check that the National Student Number (NSN) on your admission slip is the same as the number at the top of this page.

You should attempt ALL the questions in this booklet.

Make sure that you have Resource Booklet L3–PHYSR.

In your answers use clear numerical working, words, and/or diagrams as required.

Numerical answers should be given with an SI unit, to an appropriate number of significant figures.

If you need more room for any answer, use the extra space provided at the back of this booklet.

Check that this booklet has pages 2–12 in the correct order and that none of these pages is blank.

YOU MUST HAND THIS BOOKLET TO THE SUPERVISOR AT THE END OF THE EXAMINATION.

TOTAL

ASSESSOR'S USE ONLY

QUESTION ONE: CONTACTLESS PAYMENT CARDS

Mobile contactless payment systems are used in shops and restaurants throughout New Zealand.

The mobile payment machine contains a battery that can be recharged by connecting to an external 9.00 V DC power supply. The terminal voltage of the external power supply drops to 8.60 V DC when the circuit draws 0.333 A of current.

- (a) Show that the internal resistance of the external power supply is 1.20Ω .



ASSESSOR'S
USE ONLY

www.twittr.com/hashtag/cashquick

While it is recharging, the payment machine displays a charging symbol on its screen. The diagram below shows a simplified model of the charging circuit at one moment in the recharging process.

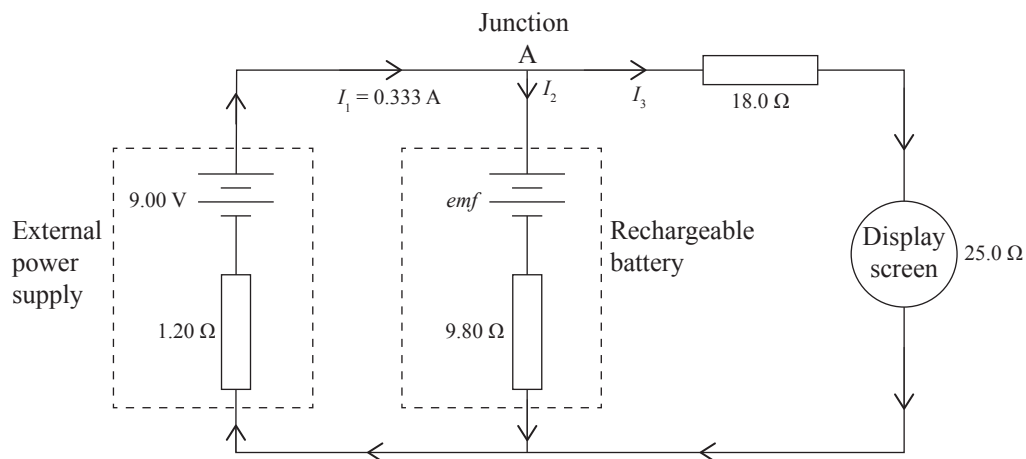

- (b) Using Kirchoff's laws, determine the emf of the rechargeable battery at this moment.

Your solution should include:

- an equation showing the relationship between I_1 , I_2 and I_3 at Junction A
- a calculation to show that $I_3 = 0.200 \text{ A}$.

(d) At the frequency 13.6×10^6 Hz, the contactless card's induction coil has a reactance of 427Ω . The contactless card circuit contains a capacitor in series with the coil that causes the circuit to resonate only at this frequency.

- State the conditions under which resonance occurs.
- Calculate the capacitance that is needed for resonance.

**This page has been deliberately left blank.
The examination continues on the following page.**

QUESTION TWO: AUTOMATIC GATES

Inductive loops are also used to sense the presence of cars. Inductive loops are wire coils embedded into the surface of the road, and are powered by an AC supply of known voltage and frequency.



www.exhibitorlist.co.uk/vision-london-2015/exhibitors.php?OSECid=21d7a0e2d99836190e5336fa549618e6



www.picswe.com/pics/induction-loop-detector-diagram-3a.html

One particular inductive loop has $4.00\ \Omega$ of resistance and is powered by a $24.0\ V_{\text{RMS}}$, $1.20 \times 10^2\ \text{Hz}$ AC power supply. The loop is a $1.60\ \text{m} \times 0.600\ \text{m}$ rectangular shape, with three coils of wire.

- (a) Calculate the peak voltage of this power supply.

- (b) The strength of the magnetic field inside the loop is $0.0413\ \text{T}$

Calculate the maximum magnetic flux in each of the three coils of wire of the inductive loop.

QUESTION THREE: COUNTING CARS

<http://ciudadanosenred.com.mx/movilidad-lo-que-no-sabias-sobre-los-topes/>

<https://parkomate.com/>

Capacitors built into rubber speed bumps can be used to sense the number of cars entering and leaving parking buildings. One particular speed bump capacitor consists of two 0.687 m^2 metal plates. When no car is present, the plates are separated by 0.0519 m of air ($\epsilon_r = 1.00$).

- (a) Show that the capacitance of the capacitor is $1.17 \times 10^{-10} \text{ F}$.

The capacitor is connected to a sensing circuit as shown below:

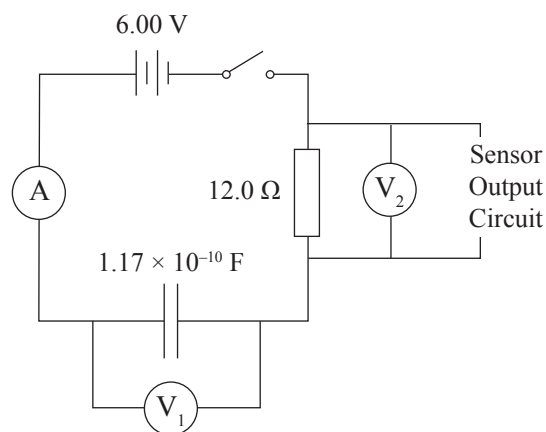

When the switch is closed, current will begin to flow and charge the capacitor plates.

- (b) Sketch a graph to show how the current changes from when the switch is closed to when the capacitor is fully charged.

Calculated values for at least two data points should be included.

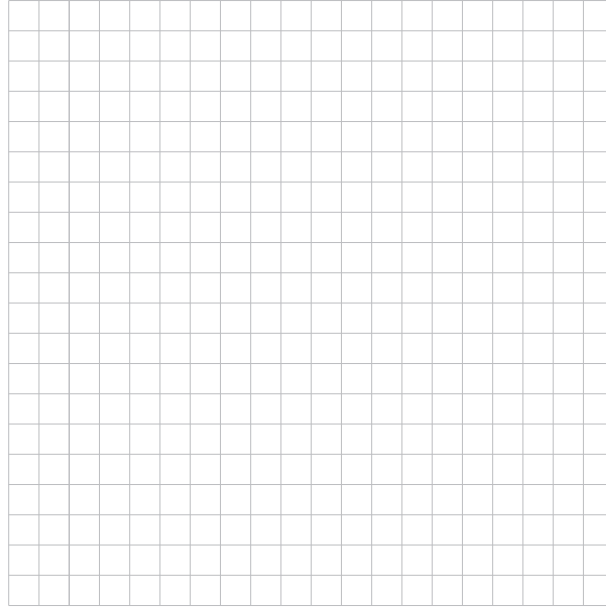

If you need to redraw this graph, use the grid on page 11.

After the capacitor has been fully charged, a car passes over the speed bump. The weight of the car pushes the capacitor plates closer together, increasing the capacitance to 2.30×10^{-10} F.

Assume the amount of the charge on each of the plates at this moment is unchanged.

- (c) Show that the voltage of the capacitor at this moment is 3.05 V.

Question Three continues on the following page.

SPARE DIAGRAMS

If you need to redraw your graph from Question Three (b), draw it below. Make sure it is clear which answer you want marked.

