

91526



NEW ZEALAND QUALIFICATIONS AUTHORITY
MANA TOHU MĀTAURANGA O AOTEAROA

3

SUPERVISOR'S USE ONLY

Level 3 Physics, 2014

91526 Demonstrate understanding of electrical systems

2.00 pm Tuesday 25 November 2014

Credits: Six

Achievement	Achievement with Merit	Achievement with Excellence
Demonstrate understanding of electrical systems.	Demonstrate in-depth understanding of electrical systems.	Demonstrate comprehensive understanding of electrical systems.

Check that the National Student Number (NSN) on your admission slip is the same as the number at the top of this page.

You should attempt ALL the questions in this booklet.

Make sure that you have Resource Booklet L3–PHYSR.

In your answers use clear numerical working, words and/or diagrams as required.

Numerical answers should be given with an SI unit, to an appropriate number of significant figures.

If you need more room for any answer, use the extra space provided at the back of this booklet.

Check that this booklet has pages 2–8 in the correct order and that none of these pages is blank.

YOU MUST HAND THIS BOOKLET TO THE SUPERVISOR AT THE END OF THE EXAMINATION.

TOTAL

ASSESSOR'S USE ONLY

QUESTION ONE: AC

The ideal transformer shown below has 3000 turns in its primary coil, and 600 turns in the secondary coil. A $240\text{ V}_{\text{rms}}$ AC power supply is connected across the primary coil. The secondary coil is connected to an external circuit.

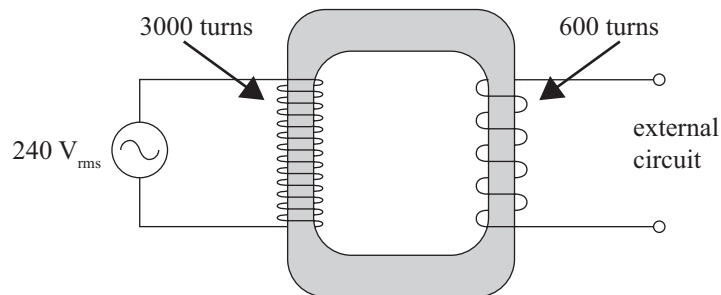

- (a) (i) Calculate the rms voltage across the external circuit.

- (ii) Calculate the peak voltage across the external circuit.

- (b) Explain why rms values are often used to describe AC voltages.

- (c) The external circuit consists of a resistor and an inductor as shown. The frequency of the power supply is 50.0 Hz.

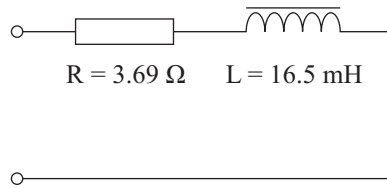

By drawing a phasor diagram, show how the impedance of the external circuit can be calculated.

- (d) A capacitor is added to the external circuit, causing the circuit to be at resonance.

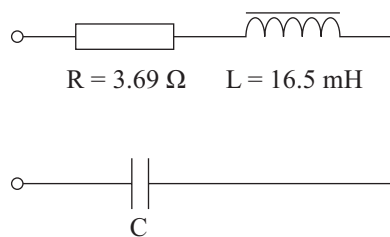

Determine the rms voltage across the capacitor.

QUESTION TWO: BATTERIES

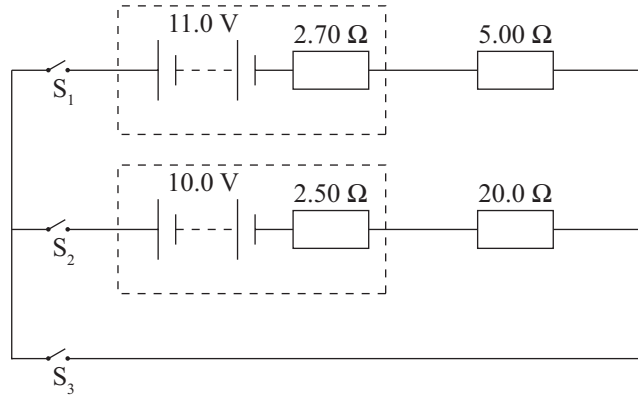

The circuit diagram shows two batteries connected into a circuit. The internal resistance, r_1 , of the 11.0 V battery is 2.70Ω , and the internal resistance, r_2 , of the 10.0 V battery is 2.50Ω .

- (a) Switches S_1 and S_2 are closed and switch S_3 is left open.

Show that the current in the circuit is 0.0331 A.

- (b) In which direction will the current be flowing through switch S_1 ?
Explain your answer.

- (c) Switch S_3 is now closed so all three switches are closed.

Show, using Kirchhoff's laws, that the current through switch S_3 is 1.87 A.

- (d) Switch S_1 is now opened, leaving switches S_2 and S_3 closed. After this circuit has been operating for some time, the 10.0 V battery starts to go flat. A student suspects that this is caused by an increase in the internal resistance.

Explain what effect a changing internal resistance has on the power delivered to the 20.0Ω resistor.

A full answer will include some sample calculations.

QUESTION THREE: ENERGY

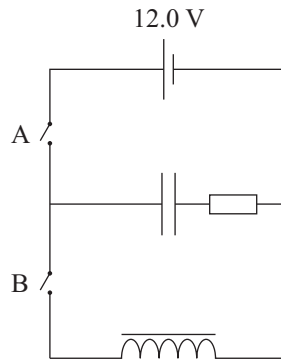

- (a) In the circuit above, switch B is kept open and switch A is closed, allowing charge to flow onto the plates of the capacitor.

Explain why the voltage of the capacitor rises to the voltage of the battery.

- (b) When the capacitor in the circuit above is fully charged, it carries a charge of $8.60 \times 10^{-3} \text{ C}$.

Calculate the energy stored in the capacitor when it is fully charged.

- (c) The graph below shows the relationship between voltage and time as the capacitor charges.

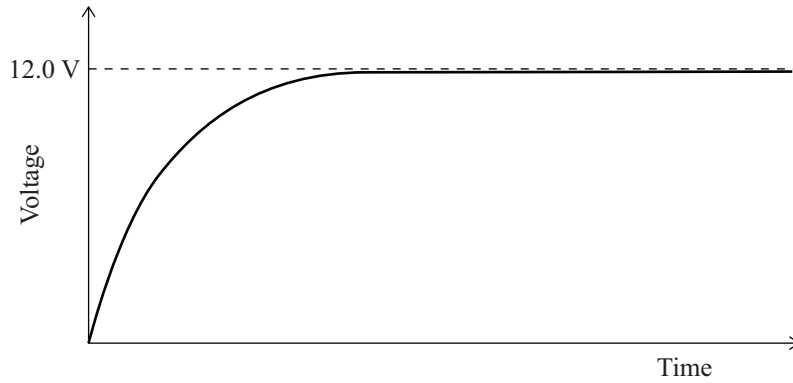

Sketch another curve on the graph to show the effect of an increased resistance on the charging of the capacitor.

Now switch A is opened and switch B is closed. The current changes with time.

- (d) Explain the effect that inductors have on currents that change with time.

- (e) Discuss how energy is stored in the capacitor and inductor at the instant switch B is closed, and then while the capacitor is discharging.
